

Indice	Edition	Modification	Date	Approuvé par
-	-	-	-	-

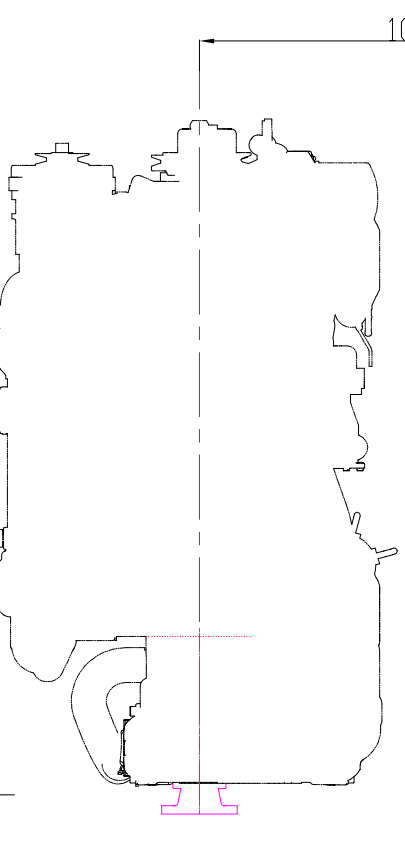
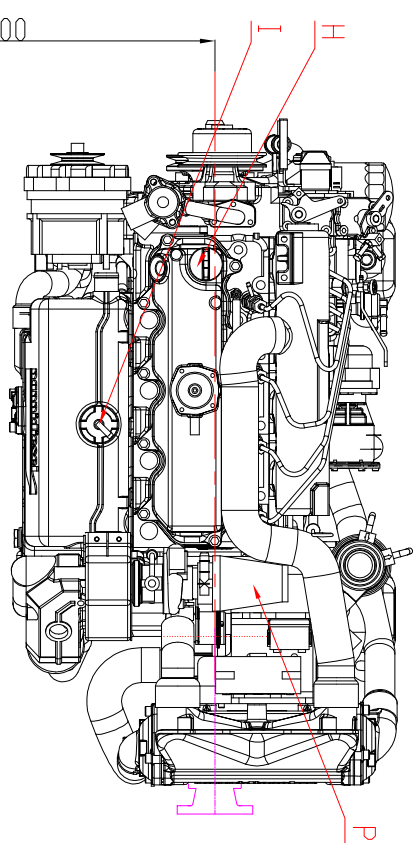
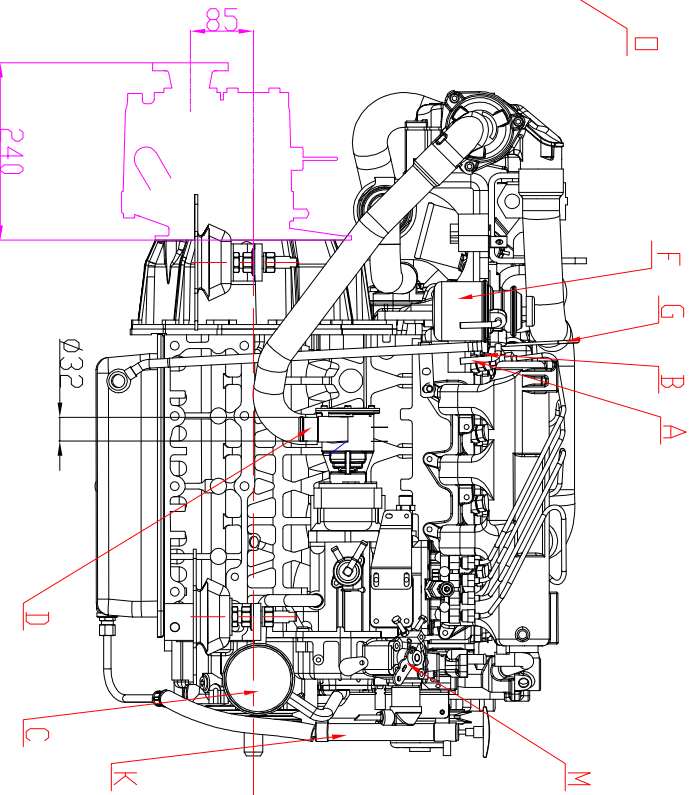
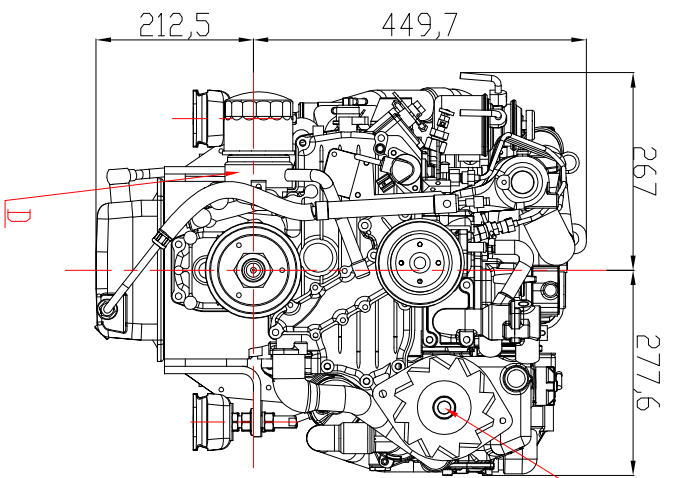
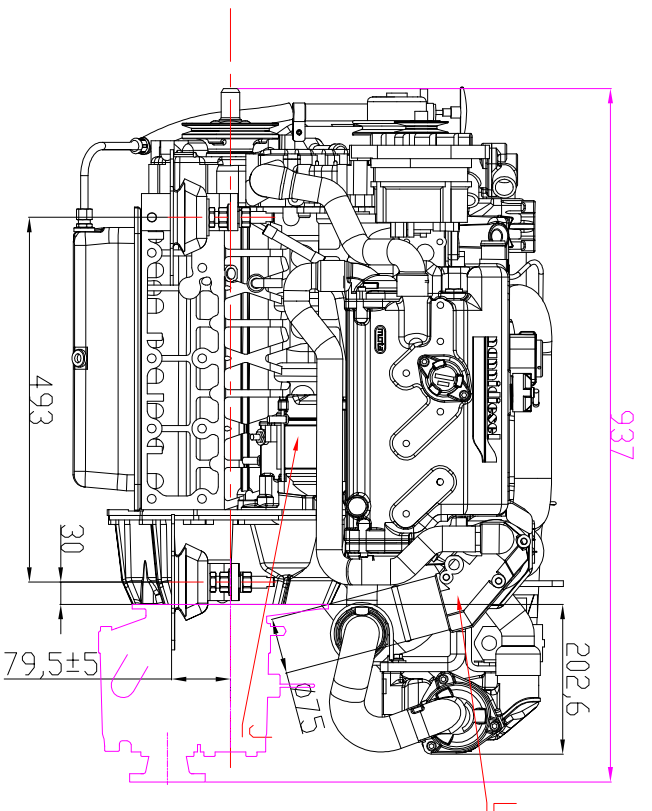
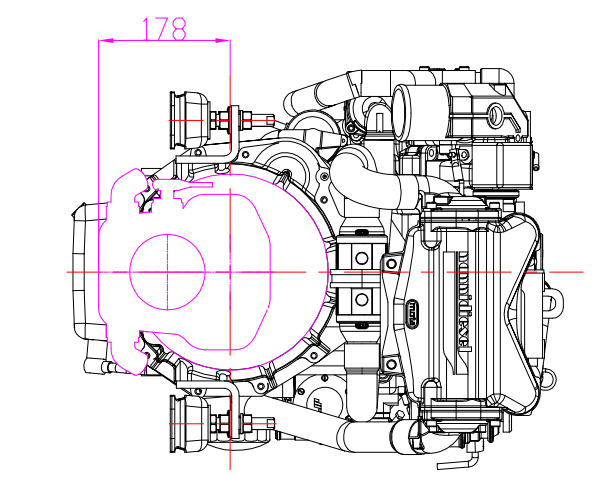
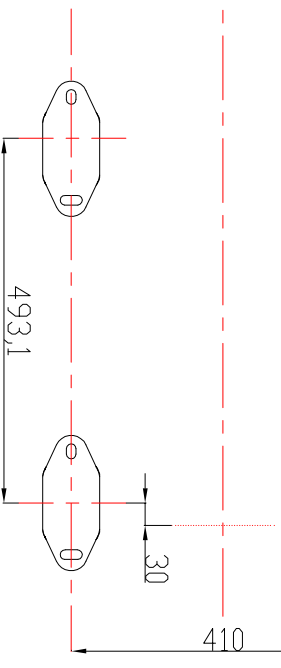
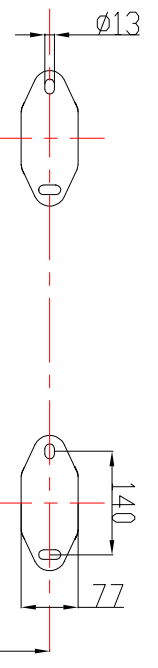

A	FUEL INLET CONNECTION Ø 8 mm
B	FUEL OUTLET CONNECTION Ø 8 mm
C	OIL FILTER
D	RADIATOR ANDEF032MM
F	FUEL FILTER
G	OIL DIP STICK
H	OIL FILLER CAP
I	COOLANT FILLER CAP
J	ENGINE STARTER
K	OIL DRAIN
L	WATER COOLED EXHAUST ELBOW
M	THROTTLE LEVER
N	THERMOSTAT
D	ALTERNATOR
P	AIR FILTER

Dessiné par	Contrôlé par	Echelle :	Format :
NC	JD	1/10	A3
Etat :		Date :	
-		-	

nmni

NANNI INDUSTRIES S.A.S
 BP 107 ZI Av Morotte 33260 LA TESTE
 Tél:(33)05 56 22 30 60 - Fax:(33)05 56 22 30 79

N4.80 TMC260

N° Dessin : N4-80
 Ind. Ed. : 1

18/09/2018

Ce document est la propriété de la NANNI Industries S.A. Duplication interdite, tous droits réservés / This document is NANNI Industries S.A. property. Duplication forbidden. All rights reserved