

# T8V.370

## Specifications



<b>Power at crankshaft</b>	272 kW [370 hp]	<b>Engine base</b>	Toyota
<b>Displacement</b>	4.5 l [275 in <sup>3</sup> ]	<b>Fuel system</b>	Direct injection High pressure Common Rail Electronically controlled
<b>Configuration</b>	8 cylinders V design 90°	<b>Air intake</b>	Twin turbocharger
<b>Operation type</b>	4 stroke Diesel	<b>Cooling</b>	Closed cooling with heat exchanger
<b>Bore &amp; Stroke</b>	86 x 96 mm [3.39 x 3.78 in]	<b>Max mounting angle</b>	7° Front up 7° Front down
<b>Compression ratio</b>	15,8:1	<b>Alternator</b>	12 Volt 120 Amp
<b>Rated speed</b>	3800 rpm	<b>Rating</b>	M6
<b>Idling speed</b>	550 rpm	<b>Emission compliance</b>	EPA marine Tier 3 RCD Stage 2 2013/53/EU
<b>Peak torque</b>	804.3 Nm		
<b>Peak torque speed</b>	2600 rpm		
<b>Dry weight</b>	435 kg [959 lbs]		

# T8V.370

272 kW [370 hp] at 3800 rpm

## TECHNICAL DESCRIPTION

### Engine block

- 8 cylinders V design 90°
- 4 valves per cylinder
- Dual overhead camshafts (DOHC)
- Watercooled exhaust manifold
- Internal balancers

### Fuel system

- Common Rail fuel injection system
- Fuel filter with hand primer
- Integrated fuel cooler

### Lubrication system

- Replaceable full-flow oil filter
- Oil dipstick
- Transmission oil cooler

### Cooling system

- Closed cooling with heat exchanger
- Gear driven self-priming raw water pump
- Coolant circulating pump
- Water cooled exhaust elbow

### Electrical system & Instrumentation

- 12V 120A alternator
- 12V Electrical system
- Complete instrumentation including key switch and alarms
- Extension cable harness with plug-in connection

### Air intake

- Twin turbocharger
- Intercooler

### Other features

- Flexible engine mounting

## Optional equipment & accessories

- Complete marine propulsion systems
- Marine transmission adaptation kits
- Throttle and shift controls
- Additional instrumentation, Flying bridge extension harness
- Complete fuel systems
- Complete exhaust systems

## RATING

- Up to 500 annual operating hours
- Load factor up to 35%
- Full power for no more than 30 minutes out of each 8 hours of operation. The remaining operation time must be at or below cruising speed

## TRANSMISSIONS

Contact your local dealer for more details and availability for transmission model and type.

## PERFORMANCE CURVES

### Power at crankshaft

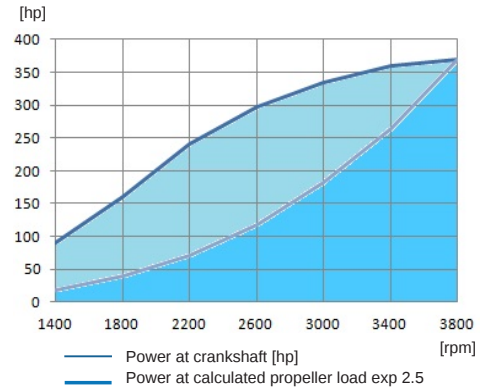

### Torque at crankshaft

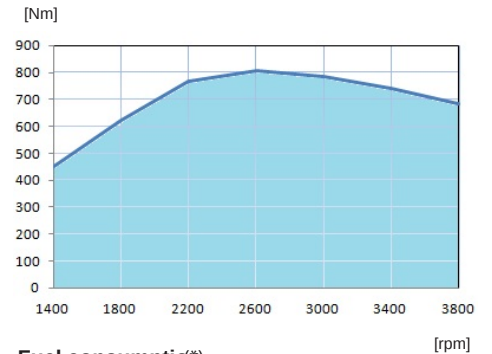

### Fuel consumption

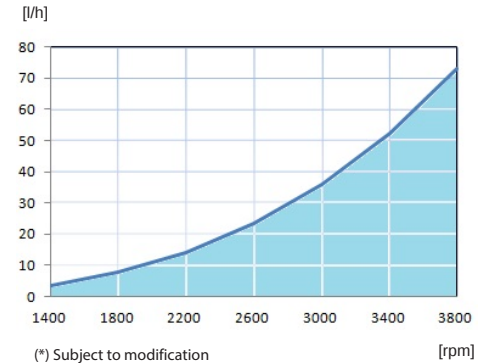

## DIMENSIONS

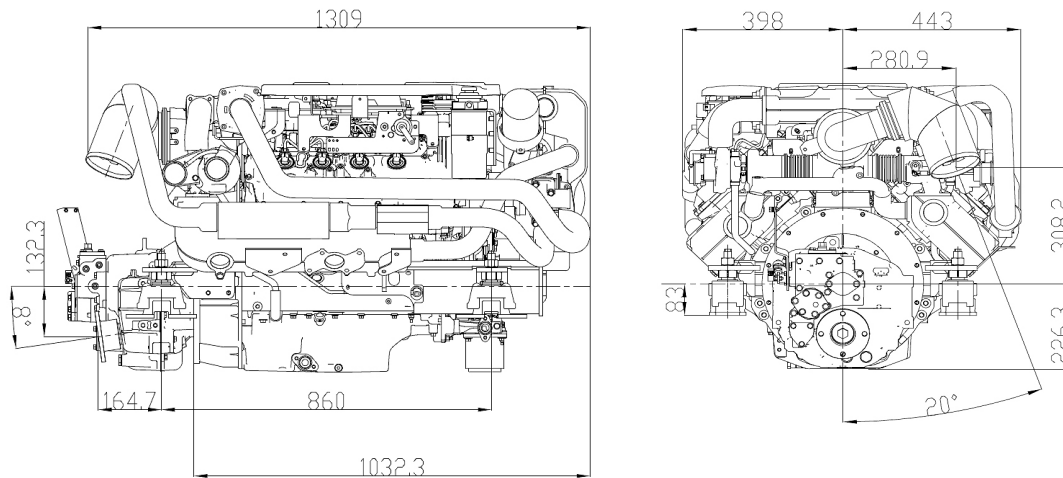

## Nanni Diesel Australia

26/17-21 Bowden St  
Alexandria, NSW. 2015 Australia  
Tel: (02) 9319 5222  
Email: engines@nannidiesel.com.au

Technical data according to ISO 8665. Specifications are subject to change without notice. Images and illustrations may show non standard equipments. All combination of equipment & accessory are not available.

20160726-B ENG